



SUPERLIFT®
S U S P E N S I O N

**6" Lift Kit for
2007 - 2017 DODGE RAM 1500 4WD
with Gas & Eco-Diesel Engine
INSTALLATION INSTRUCTIONS**

THANK YOU FOR CHOOSING SUPERLIFT FOR ALL YOUR SUSPENSION NEEDS!!

INTRODUCTION

Installation requires a professional mechanic.

Prior to beginning, inspect the vehicles steering, driveline, and brake systems, paying close attention to the suspension link arms and bushings, sway bars and bushings, tie rod ends, pitman arm, ball joints and wheel bearings. Also check the steering sector-to-frame and all suspension-to-frame attaching points for stress cracks. The overall vehicle must be in excellent working condition; repair or replace all worn parts.

Read instructions several times before starting. Be sure you have all needed parts and know where they install. Read each step completely as you go.

NOTES:

- Prior to beginning the installation, check all parts and hardware in the box with the parts list below. If you find a packaging error, contact Superlift directly. Do not contact the dealer where the system was originally purchased. You will need the control number from each box when calling; this number is located at the bottom of the part number label and to the right of the bar code.
- Wheels - An 18" Diameter or Larger wheel Must Be Used with this system.
 - * Factory 17" and 18" wheels Do NOT Work.Wheel recommendations:
 - * 18" diameter x 9" wide (maximum) with a maximum backspacing of 5", or
 - * 20" diameter x 9" wide (maximum) with a maximum backspacing of 5-1/2"
- Tires - 37" diameter x 12.50" wide. Do NOT Fabricate any components to gain additional suspension height.

- Front end realignment is necessary.
- A foot-pound torque reading is given in parenthesis () after each appropriate fastener
- Prior to drilling or cutting, check behind the surface being worked on for any wires, lines, or hoses that could be damaged. Prep all cutting surfaces by removing all debris and frame coatings.
- After drilling, file smooth any burrs and sharp edges.
- Prior to operating a torch or saw, protect any heat-sensitive components located in the immediate area by covering them with a water-saturated cloth. Most undercoating are flammable but can be extinguished using a water-filled spray bottle. Have a spray bottle and an ABC rated fire extinguisher on hand.
- Paint or undercoat all exposed metal surfaces.
- Prior to attaching components, be sure all mating surfaces are free of grit, grease, undercoating, etc.
- A factory service manual should be on hand for reference.
- Use the check-off box “” found at each step to help you keep your place. Two “” denotes that one check-off box is for the driver side and one is for the passenger side. Unless otherwise noted, always start with the driver side.

Part Number	Qty. per Kit	Description	New Attaching Hardware	Qty. per Bracket	Hardware Bag Number
66-01-4594	1	knuckle, driver	threadlocker	1	77-4594-2
66-02-4594	1	knuckle, passenger	threadlocker	1	77-4594-2
55-62-4594	1	differential bracket, driver front	12mm x 40mm bolt 12mm flat washer 12mm stover nut 12mm lock washer	4 6 2 2	77-4603-1
55-03-4603	1	differential bracket, driver rear	12mm x 50mm bolt 12mm lock washer 12mm flat washer 12mm nut	3 3 6 3	77-4603-1
55-63-4594	1	differential bracket, passenger	1/2" x 2-1/4" bolt 1/2" stover nut 1/2" sae flat washer 12mm stover nut 12mm flat washer 12mm x 70mm bolt	2 2 4 2 2 2	77-4603-1
55-05-4603	1	differential actuator bracket			
55-46-4594	1	crossmember front	18mm x 150mm bolt 3/4" sae flat washer 2" x 1-1/2" x 3/16" lockout tabs 18mm nyloc nut	2 4 2 2	77-4594-2
55-49-4594	1	crossmember rear	18mm x 150mm bolt 3/4" sae flat washer 2" x 1-1/2" x 3/16" lockout tabs 18mm nyloc nut	2 4 2 2	77-4594-2
55-08-4594	1	belly pan	3/8" x 1" countersunk bolt 3/8" flange nut	6 6	77-4594-4
55-10-4594	2	strut spacer	7/16" flange nut 7/16" sae flat washer	6 6	77-4594-3
66-09-4594	2	preload spacer 1-1/2" aluminum			
or					
55-10-4594	2	outdoorsman strut spacer (sold Separately 4594)			
or					
BE5-F812-H0	2	Bilstein struts			
55-11-4594	1	brake line bracket, front passenger	3/8" flange nut 3/8" x 1" bolt 1/4" x 3/4" bolt 1/4" nyloc nut	1 1 1 1	77-4594-3
55-12-4594	1	brake line bracket, front driver	3/8" flange nut 3/8" x 1" bolt 1/4" x 3/4" bolt 1/4" nyloc nut	1 1 1 1	77-4594-3
55-23-4640	2	sway bar link, front	7/16" sae washer	6	77-4594-3
66-04-4603	1	driveshaft spacer, front	12mm x 50mm bolt	4	77-4594-3
55-47-4594	1	track bar bracket, rear	7/16" x 1-1/4" bolt sleeve, 1-1/8" OD x 1-7/16" Long 7/16" sae washer 9/16" x 3-1/2" bolt 9/16" sae washer 9/16" nyloc nut 7/16" nyloc nut	2 1 4 1 2 1 2	77-4594-13
55-22-4594	1	track bar bracket, rear support			
55-64-4594	2	sway bar/ brake line bracket, rear	7/16" x 1" bolt 7/16" sae washer 7/16" nyloc nut 5/16" x 1" bolt 5/16" sae washer 5/16" nyloc nut	2 4 2 2 4 2	77-4594-13
55-37-4594	1	bump stop extension, driver rear	3/8" x 1" bolt 3/8" sae washer 3/8" nyloc nut	2 2 2	77-4594-6
55-36-4594	1	bump stop extension, passenger rear	3/8" x 1" bolt 3/8" sae washer 3/8" nyloc nut	2 2 2	77-4594-6
55-55-4594	1	link arm bracket, driver	1/2" x 1-1/4" bolt 5/8" x 4-1/2" bolt 5/8" x 4" bolt 5/8" sae washer 5/8" stover nut 55-12-4540 tab nut	1 1 1 4 2 1	77-4594-5
55-56-4594	1	link arm bracket, passenger	1/2" x 1-1/4" bolt 5/8" x 4-1/2" bolt 5/8" x 4" bolt 5/8" sae washer 5/8" stover nut 55-12-4540 tab nut	1 1 1 4 2 1	77-4594-5
02-141	2	coil spring, rear			

FRONT PROCEDURE

NOTE: Save all factory components and hardware for reuse, unless noted.

1) PREPARE VEHICLE...Chock rear tires and place transmission in neutral. Raise front of vehicle with a jack and secure a jack stand beneath each frame rail. Ease the frame down onto the stands and place transmission in park. Remove front tires. {Lug Nuts 22mm}

Disconnect the battery.

2) FRONT DIFFERENTIAL SKID PLATE AND DRIVESHAFT...If equipped, remove the factory front differential skid plate and discard. Disconnect the front driveshaft from the differential then secure driveshaft up and out of the way.

3) SWAY BAR LINKS...Disconnect the upper end of the sway bar links from the sway bar body; leave the lower ends attached to the lower control arm.

Perform steps 4 through 7 one side at a time.

4) WHEEL SPEED SENSORS...Detach the Wheel Speed Sensor (WSS) wire at the following points, and in this order:

A) At rubber brake hose

B) At rear leg of upper control arm

C) At engine compartment side of the inner fenderwell. This attachment point is just above attachment point "B", and is accessed by pulling the plastic inner fender outboard slightly. Point "C" is also a WSS wire plug / connector; disconnect the WSS wire here.

5) KNUCKLES...Remove the brake caliper from the rotor and secure it away from the work area. **NOTE:** Do not let calipers hang from brake lines.

Remove the front rotor from the hub. Remove the retaining nut from the center of the bearing hub.

Loosen, but do not remove, the upper control arm bolts.

Using the appropriate puller tool, disconnect the upper and lower ball joints and outer tie rod end from the knuckle. Remove knuckle. The wheel speed sensor wire remains on the factory knuckle for now.

6) STRUTS... Loosen, but do not remove, the lower control arm bolts. Remove the lower strut bolt. Remove the three upper strut assembly bolts. Remove strut.

7) LOWER CONTROL ARMS...Remove the lower control arm's two alignment cam bolt assemblies then remove the lower control arm.

Repeat steps 4 through 7 on opposite side.

8) REAR CROSSMEMBER...Remove the factory lower control arms' rear crossmember.

9) □ DIFFERENTIAL... Disconnect all electrical lines from differential. Unbolt front driveshaft and secure it up and out of the way. Support the differential and remove all differential-to-frame mounting hardware. Remove differential assembly.

10) TRIMMING FRONT AND REAR / LOWER CONTROL ARM MOUNT...

□ [Illustration 1A] The front driver and passenger side lower control arm mount must be trimmed. Measure down 1" from the bottom edge of the slot and mark a line parallel to the slot. Cut the frame through the front side only along the marked line using a cut-off wheel or Sawz-all. After cutting, clean and paint all exposed areas.

□ [Illustration 1B] The passenger side factory rear / lower control arm mount must be trimmed as shown. Measure down from the bottom edge of the slot and mark a line parallel to the slot. Cut the frame through the front side only along the marked line using a cut-off wheel or Sawz-all. After cutting, clean and paint all exposed areas.

□ [Illustration 1C] The driver side factory rear / lower control arm mount must be trimmed as shown. Measure to the inside 1-3/4" from inside edge of slot and mark a line perpendicular to the bottom edge of the slot. Cut the frame through all sides along the marked lines (front, top and back sides) using a cut-off wheel or Sawz-All. After the first cut, measure down from the bottom edge of the slot 15/16" and mark and line parallel with the bottom edge of the slot on the front side of the factory

Illustration 1A

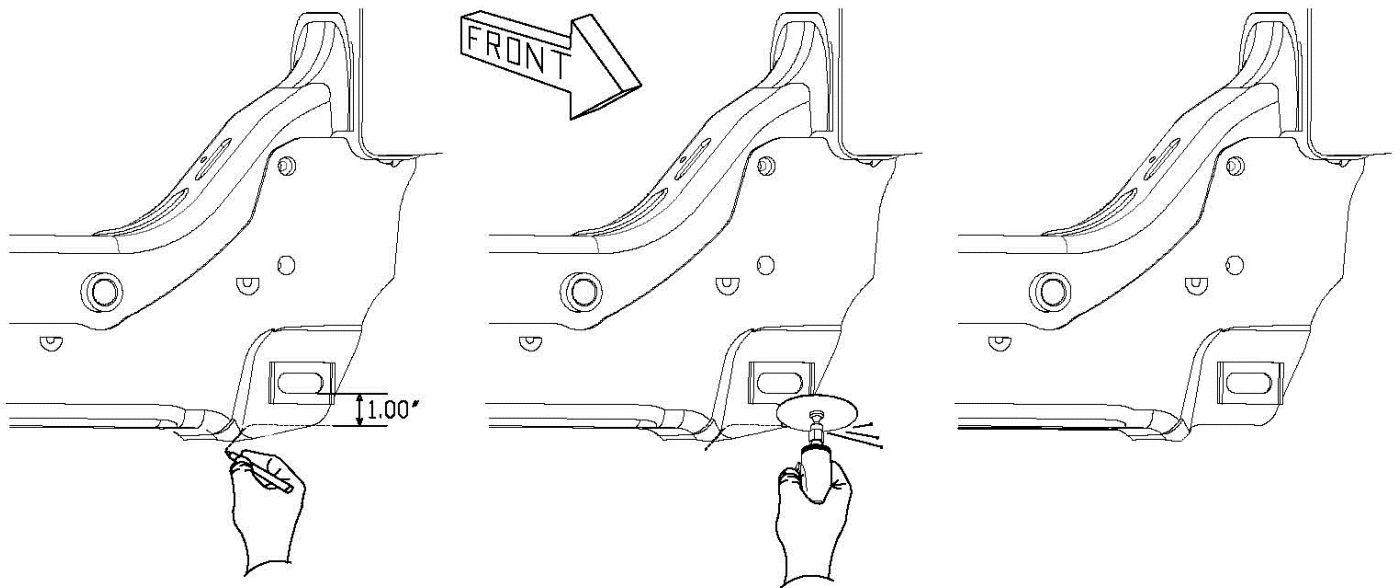

mount. Cut the frame through the front side only along the marked line using a cut-off wheel or Sawz-All. After cutting, clean and paint all exposed areas.

Illustration 1B

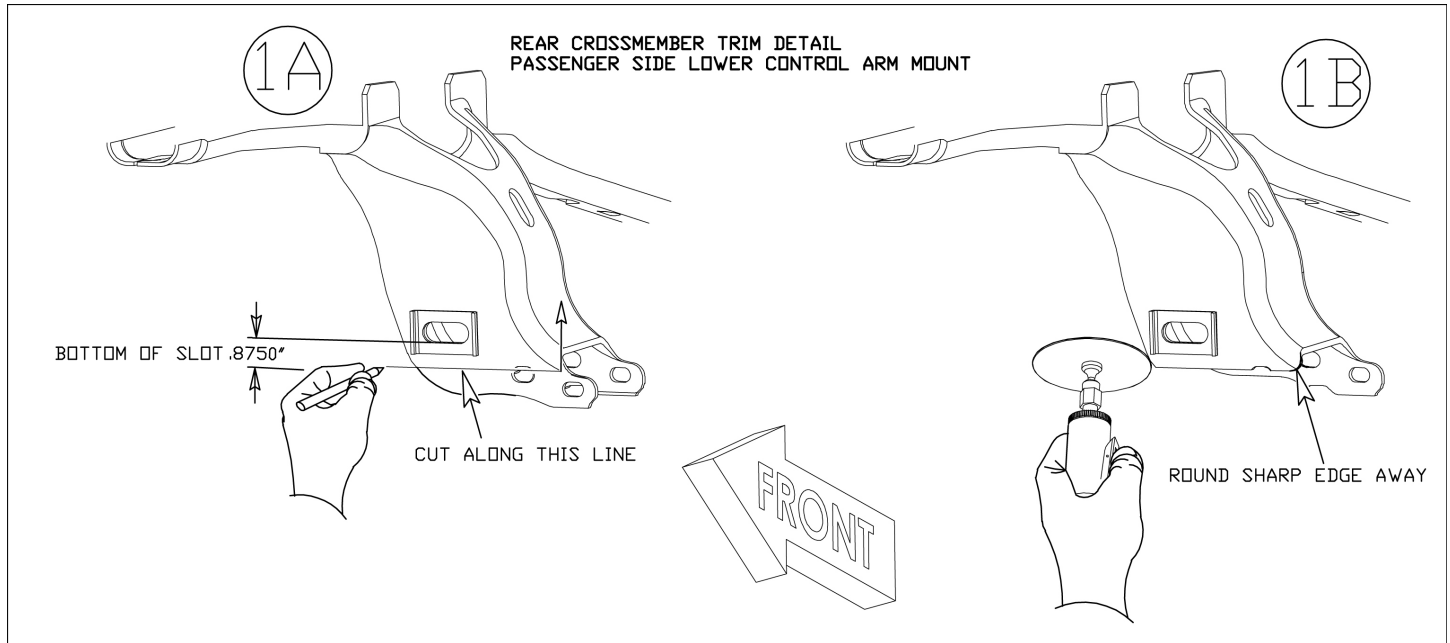
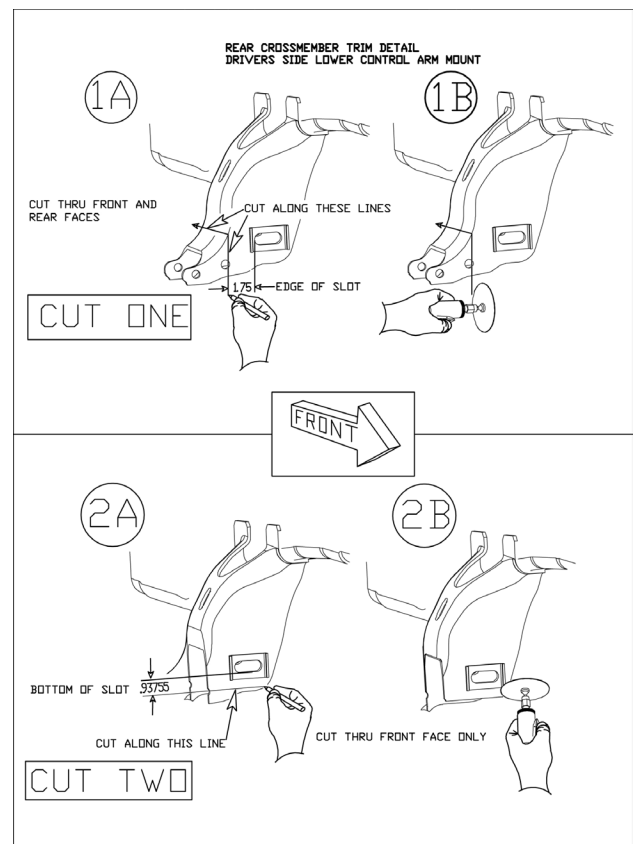

Illustration 1C



11) DIFFERENTIAL BRACKETS...[Illustration 2]

□ Loosely attach the driver side / front differential bracket (SL# 55-62-4594) to the frame using the supplied 12mm x 40mm bolts, lock washers, and flat washers. The bracket has an arrow at top and points to the front. Do not tighten.

□ [Illustration 3] Loosely attach the driver side / rear differential bracket (SL# 55-03-4603) to the frame using the factory bolts, supplied flat washers and supplied nuts. Do not tighten.

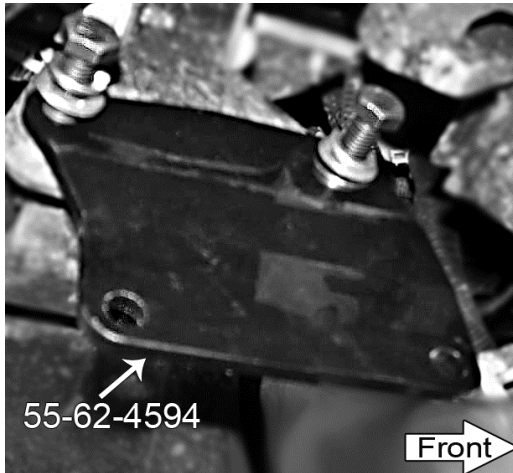
Illustration 2**Illustration 3**

□ [Illustration 4] Loosely attach the passenger side differential bracket (SL# 55-63-4594) and the differential actuator bracket (SL#55-05-4603) to the frame using the supplied 12mm x 70mm bolts and flat washers and Stover nuts. Do not tighten. Note that the actuator bracket should be placed between the 55-63-4594 and the bolt head with the third hole positioned on the passenger side.

12) □ □ CV AXLES...On each side, disconnect the inner CV axle assembly from the differential. Use two pry bars, positioned between the inner CV and the differential housing, to free the axles.

13) INSTALL DIFFERENTIAL AND SUPERLIFT REAR CROSSMEMBER (SL# 55-49-4594)...

□ **Position the differential in the frame** - Loosely attach the differential to the Superlift driver side / front bracket (SL#55-03-4594) using the supplied 12mm x 50mm bolts, flat washers (on both nut and bolt head sides) and Stover nuts. Do not tighten. The differential is attached to the remaining Superlift brackets in later steps.

□ **Superlift rear crossmember, passenger side** - Raise the passenger side of the differential housing which will allow you to mate the passenger side of the Superliftcrossmember - to - frame. Insert the supplied 18mm x 150mm bolt and flat washer from the front, through the factory mount crossmember. Position the 2" x 1-1/2" x 3/16" thick lockout tab onto the bolt; the tab seats in what was the factory rear cam washer's location. Install the supplied flat washer then the supplied 18mm Nyloc nut. Do not tighten. Note the crossmember goes inside of the factory mount.

Illustration 4

- Superlift rear crossmember, driver side** - Position the driver side of the Superlift crossmember into the frame. Insert the supplied 18mm x 150mm bolt and flat washer from the front, through the factory mount and crossmember. Position the 2" x 1-1/2" x 3/16" thick lockout tab onto the bolt; the tab seats in what was the factory rear cam washer's location. Install the supplied flat washer then the supplied 18mm Nyloc nut. Do not tighten. Note the crossmember goes inside of the factory mount.
- Differential - to - Superlift passenger side bracket** - Loosely attach using the supplied 1/2" x 2-1/4" bolts, flat washers (on both nut and bolt head sides) and Stover nuts. Do not tighten.
- Differential - to - Superlift driver side / rear bracket** - Attach using the three supplied 12mm x 40mm differential bolts and the supplied nuts.
- Tighten all differential hardware to (70) in the order listed: the four bolts securing the driver side / front bracket ; the four bolts securing the passenger side bracket; the six bolts securing the driver side / rear bracket. Leave the two crossmember - to - frame bolts loose at this time.
- Insert the 5/16" vacuum line adapter (SL# 23-3205) and new vacuum line (SL# 18-9690). Reconnect the electrical lines; retaining clips may need to be removed to create enough "slack" to reconnect.

14) **SUPERLIFT FRONT CROSSMEMBER (SL# 55-46-4594)...**

Position the Superlift crossmember into the frame; make sure the tab with the skid plate holes are towards the rear of the vehicle. Insert the supplied 18mm x 150mm bolt and flat washer from the front, through the factory mount and crossmember. Position the 2" x 1-1/2" x 3/16" thick lockout tab onto the bolt; the tab seats in what was the factory rear cam washer's location. Install the supplied flat washer then the supplied 18mm Nyloc nut. Do not tighten. Note the crossmember goes inside of the factory mount.

15) FRONT DRIVESHAFT...[Illustration 3] Install driveshaft spacer (SL# 66-04-4603) between the differential mounting flange and the driveshaft using the supplied 12mm x 50mm bolts. Apply threadlocker to the bolts before installation. Tighten (85).

Perform steps 16 through 20 one side at a time.

16) **LOWER CONTROL ARMS...**

NOTE: It is possible to incorrectly install the driver side lower control arm on the passenger side of the vehicle, and vice-versa. When the control arm is located properly, the sway bar links will be positioned towards front of vehicle, and the lower ball joint stud points down.

- Loosely install the factory lower control arm reusing the factory cam bolts assemblies. Insert bolts from the front with the cam lobes in the upright / centered position. Do not tighten.

17) **SUPERLIFT COIL SPRING SPACERS...**

Locate the factory strut assembly. Use a paint marker to scribe three vertically aligned indexing marks on the outboard side of the assembly. Mark: 1) the outboard facing side of the upper strut mounting plate, 2) the top (exposed) coil spring wrap, 3) the center of the lower strut eye mount.

- WARNING!** The coil is under extreme pressure and severe bodily injury may occur if the coil spring is disassembled without using a suitable coil spring compressor. Compress the coil spring

until the strut body has approximately 3/8" of movement. Remove the upper strut mounting plate retaining nut. **NOTE:** Do not use an impact gun to remove the retaining nut; this may damage the strut shaft.

- Remove the washer then the strut's upper bushing half.
- Remove the strut's upper mounting plate then the factory coil spring isolator.
- Carefully remove the strut cylinder from the coil spring. **NOTE:** Inspect the strut assembly for any damage or fluid leakage. Replace if necessary.

IF REPLACEMENT BILSTEIN STRUTS WERE PURCHASED, SKIP TO STEP 17A.

- Position the strut cylinder back into the compressed coil spring. Align the indexing marks on the lower strut eye mount and the coil spring.

- [Illustration 6] Assemble the top end of the strut in this order:

- A) Position the spring isolator on top of the coil spring.
- B) Position the supplied 1-1/2" coil spacer (SL# 66-09-4594) or for Outdoorsman models position the 3/4" coil spacer (SL# 66-33-4594) on top of the isolator.
- C) Position the strut upper mounting plate on top of the Superlift® coil spacer. Align the plate indexing mark with the indexing marks on the coil spring and shock eye.
- D) Install the factory bushing half, washer, and nut.
- E) Tighten the strut mounting stem (20).

- Slowly decompress the coil spring on the strut assembly while ensuring that the coil spring remains seated correctly in its lower seat and that all three index marks remain aligned.

- Slowly decompress the coil spring on the strut assembly. Make sure that the spring is seated correctly into the strut assembly and aligned with the previously scribed index mark on the upper strut mounting plate.

- Position the strut spacer (SL# 55-10-4594) onto the top of the factory strut using the factory hardware. Tighten (45).

- Install the strut assembly by first loosely attaching the strut's upper studs to the factory frame mount using the supplied 7/16" SAE flat washers and Stover nuts; do not tighten. Now raise the lower control arm, and insert the factory lower strut hardware. Tighten the upper hardware (45). Do

Illustration 6

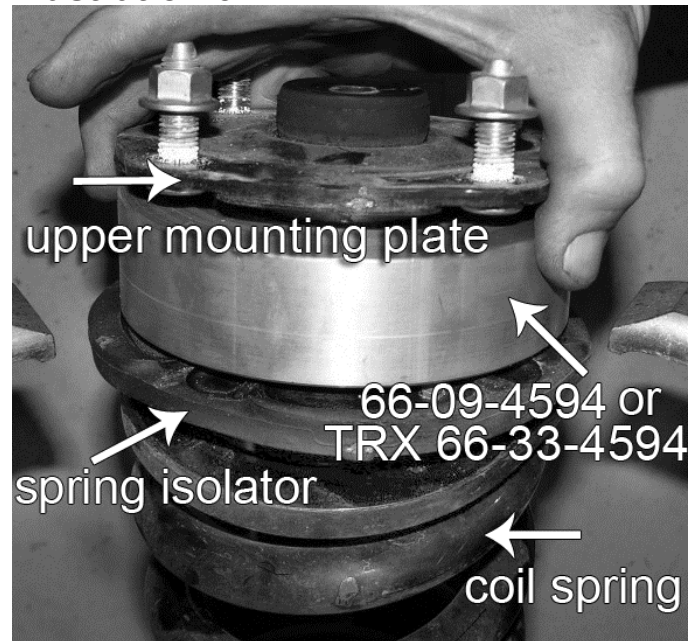

Illustration 6A

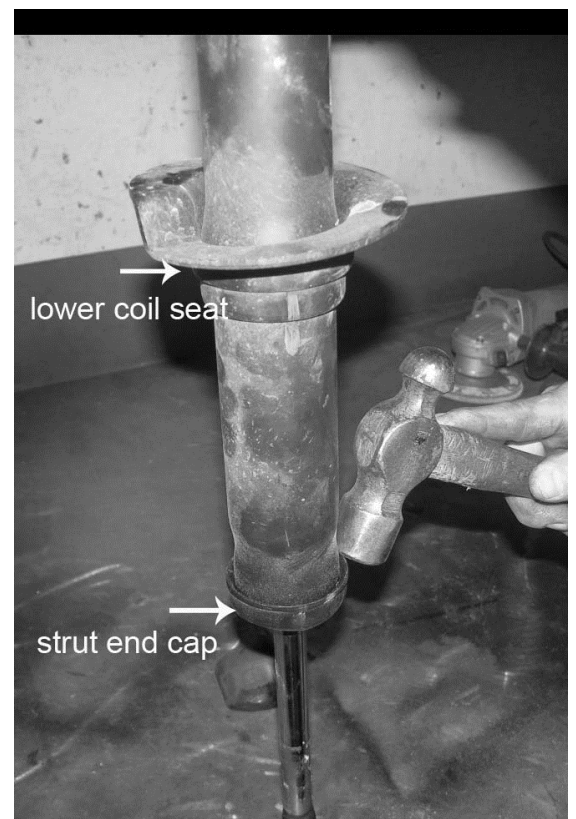
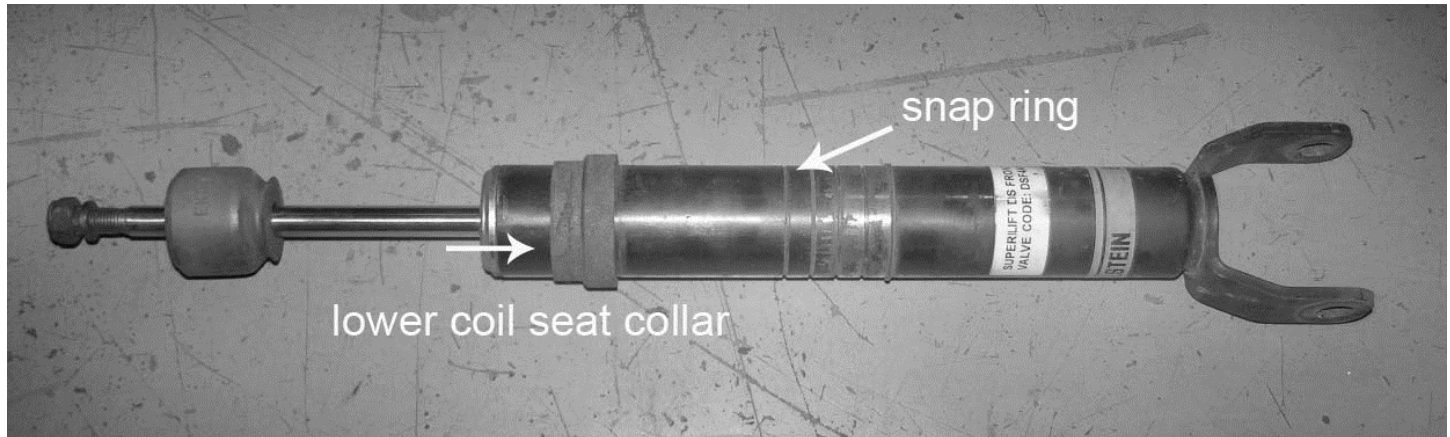

Illustration 6B

not tighten the lower strut hardware at this time.

IF REPLACEMENT BILSTEIN STRUTS WERE NOT PURCHASED, SKIP TO STEP 18.

17A) REPLACEMENT STRUTS... [Illustration 6A] Once the strut has been removed, slide the rubber snubber from the shaft, stand the strut up on the shaft end and carefully remove the strut end cap, then remove the lower coil seat

[Illustration 6B] Position the snap ring on the new strut in the end groove closest to the shaft, then slide the lower seat collar onto the snap ring. The collar may need to be carefully tapped in place with a hammer. Slide the lower coil seat onto the collar and tap into place.

Position the machined spacer on the shock body followed by the lower coil seat, insert the shock inside the coil and rotate the coil until the coil is seated properly in the lower coil seat. Install the nyloc nut and tighten.

Slowly decompress the coil spring on the strut assembly. Make sure that the spring is seated correctly into the strut assembly.

Position the strut spacer (SL# 55-10-4594) onto the top of the factory strut using the factory hardware. Tighten (45).

Install the strut assembly by first loosely attaching the strut's upper studs to the factory frame mount using the supplied 7/16" SAE flat washers and Stover nuts; do not tighten. Now raise the lower control arm, and insert the factory lower strut hardware. Tighten the upper hardware (45). Do not tighten the lower strut hardware at this time.

Repeat step on opposite side

18) **CV AXLES...** Insert the inner CV axle shaft into the differential then push firmly to engage CV axle shaft retaining ring.

19) BRAKE LINE / HOSE RELOCATION... [Illustration 7]

Locate where the upper end of the rubber brake hose passes through the frame and connects to a metal brake line. Use the appropriate tool (ex: cut-off wheel) to cut a notch in the frame to allow removal of the brake hose / line connector. Take care NOT to damage the brake line / hose. Re-

move the brake line bracket-bolt then free the line / hose connector from frame.

□□ There are a couple of bends in the metal line, just above the line / hose connector. Carefully re-form (straighten-out) the bends, as needed, to allow the factory brake line bracket to mate with the Superlift bracket. DO NOT kink the line. Attach the factory brake line bracket to the Superlift brake line bracket (SL# 55-12-4594 driver and 55-11-4594 passenger) using the supplied 1/4" x 3/4" bolt and Nyloc nut. Attach Superlift brake line bracket - to - frame using the supplied 3/8" x 1" bolt and Flange nut in the top hole and the factory hardware in the bottom hole. Tighten the 3/8" hardware (30). Tighten the factory and 1/4" hardware (95 In. Lbs.)

Illustration 7

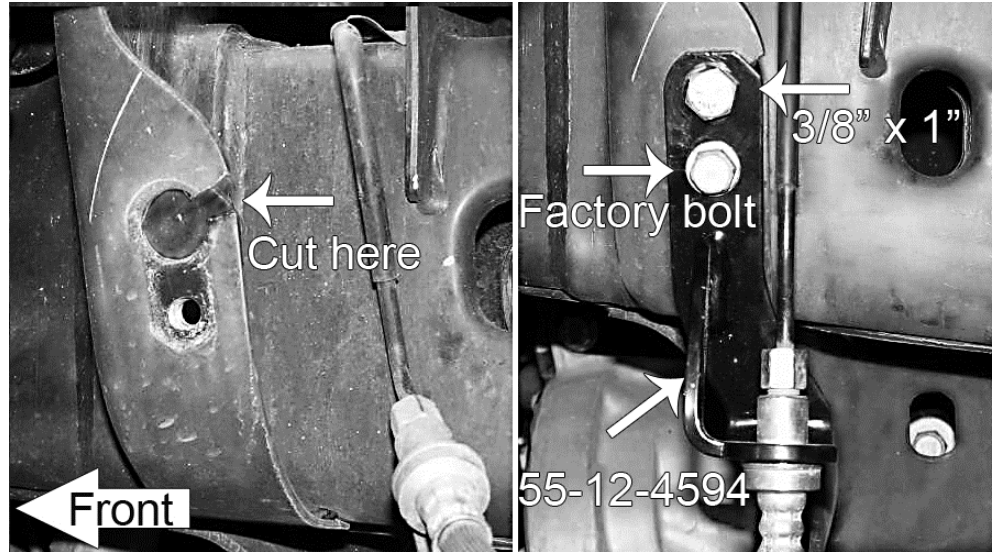

INSIDE VIEW

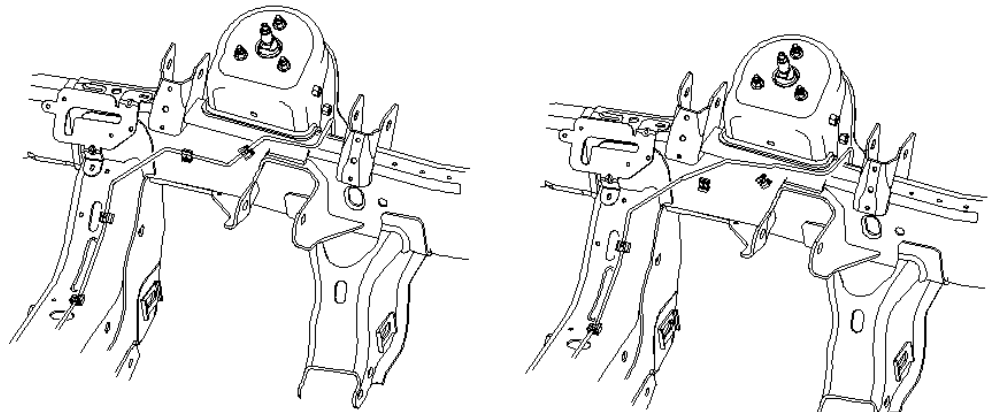

BEFORE

AFTER

20) SUPERLIFT KNUCKLE INSTALLATION...

□□ Remove the bolt that secures the Wheel Speed Sensor (WSS) wire mounting bracket to the factory knuckle. Attach this bracket to the Superlift knuckle in the same orientation as factory.

□□ Remove the hub assembly and dust shield from the factory knuckle. Do not disconnect the WSS wire from the hub assembly.

□□ Position the factory hub assembly and dust shield onto the new Superlift knuckle (SL# 66-01-4594 driver and 66-02-4594 passenger). The hub must be positioned with the WSS wire routed forward and inside the relief machined into the knuckle face. Apply threadlocker to the factory hardware then fasten hub assembly and dust shield to the

Illustration 8

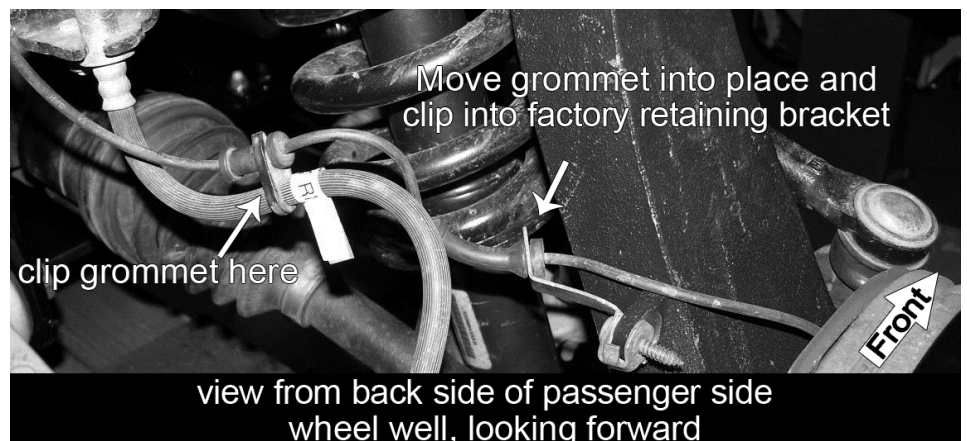

view from back side of passenger side wheel well, looking forward

Superlift knuckle. Tighten (95).

□□ [Illustration 8] Route the WSS wire to the mounting bracket on the knuckle, as shown. The rubber grommet on the WSS wire must be shifted. Lubricate the WSS wire and rubber grommet with a detergent-based cleaner (ex: Windex, Formula 409), which allows the WSS wire to slide easily through the rubber grommet. When satisfied with routing, insert the WSS wire / rubber grommet into the mounting bracket.

□□ Install knuckle onto vehicle. Attach the lower ball joint first then slide the CV axle shaft through the hub bearing. Next connect the upper ball joint and tie rod end. Reuse the factory hardware, and apply threadlocker to all. Tighten the lower ball joint nut (85), upper ball joint nut (50), CV axle shaft nut (100) and the tie rod nut (85).

□□ Install the brake rotor and caliper using the factory hardware. Apply threadlocker to caliper bolts. Tighten (130).

□□ Route / reattach the Wheel Speed Sensor (WSS) wire at the following points, and in this order. Again, it will be necessary to lubricate the grommets / WSS wire to allow movement:

- A) At rubber brake hose
- B) At rear leg of upper control arm
- C) Reconnect the WSS wire plug / connector. Do not reattach the connector to the inner fenderwell.

Repeat steps 16 through 20 on opposite side.

21) □□ ANTI-SWAY BAR LINK EXTENSIONS...Apply anti-seize to the factory anti-sway bar link threads. Install three 7/16" SAE washers per side then install the anti-sway bar link extensions (SL# 55-23-4640). Reuse factory bushings and hardware. Attach anti-sway bar links to anti-sway bar body. Tighten until bushings swell slightly.

22) □ BELLY PAN...[Illustration 9] Attach the belly pan (SL# 55-08-4594) to the Superlift lower control arm crossmembers using the six supplied 3/8" x 1" countersunk bolts and Flange nuts. Tighten (30). Clean the front lip of the belly pan with the supplied alcohol pad and install the Superlift badge.

□□ Tighten all four crossmember - to - frame bolts (75).

23) □□ TIRES / WHEELS...[Illustration 10] Tighten the lug nuts in the sequence shown (130).

Illustration 9



Illustration 10



WARNING: When the tires / wheels are installed, always check for and remove any corrosion, dirt, or foreign material on the wheel-mounting surface, or anything that contacts the wheel-mounting surface (hub, rotor, etc.). Installing wheels without the proper metal-to-metal contact at the wheel mounting surfaces can cause the lug nuts to loosen and the wheel to come off while the vehicle is in motion.

WARNING: Retighten lug nuts at 500 miles after any wheel change, or anytime the lug nuts are loosened. Failure to do so could cause wheels to come off while vehicle is in motion.

Lower vehicle to the floor. The suspension is now supporting vehicle weight.

24) TORQUE CONTROL ARMS AND STRUTS...Tighten the lower control arm bolts (110). Tighten the lower strut bolts (155). Tighten the upper control arm bolts (130).

25) CLEARANCE CHECK...Raise the vehicle back onto jack stands and secure as per step 1. With the suspension “hanging” at full extension travel, cycle steering lock-to-lock and check all components for proper operation and clearances. Pay special attention to the clearance between the tires / wheels and knuckles, brake hoses, wiring, etc.

Lower the vehicle to the floor.

REAR PROCEDURE

26) PREPARE VEHICLE...Before raising the rear of the vehicle:

Disconnect the upper end of the track bar. Loosen, but do not remove, the track bar at the driver side axle mount.

Disconnect the upper ends of the anti-sway bar links where they attach to the frame.

Disconnect the brake line mount and wheel speed sensor. Both are located on the frame, behind the coil spring's upper mount.

Remove the bolt securing the wire hanger bracket that captures the parking brake cables. This hanger is bolted to the driver side, lower suspension link arm. Retain hardware.

27) RAISE REAR OF VEHICLE...Position a jack beneath the center of the rear axle then raise rear of vehicle. Secure jack stands beneath the frame rails just forward of the rear springs. Chock front tires to prevent any possibility of movement. Remove rear tires.

28) SHOCKS AND COIL SPRINGS...Remove shock absorbers. Lower the axle just enough to allow removal of coil springs.

29) SUSPENSION LINK ARMS...[Illustration 10, 11, & 12] Perform this step one side at a time.

Loosen, do not remove, all four suspension link arms where they attach to the axle. Disconnect all four link arms from the frame.

□□ Position the Superlift link arm relocation bracket (SL# 55-55-4594 driver and 55-56-4594 passenger) as shown then attach as follows using supplied hardware. No hardware is tightened at this time.
A) At lower factory link arm mount use 5/8" x 4" bolt, SAE flat washers (on both nut and bolt head

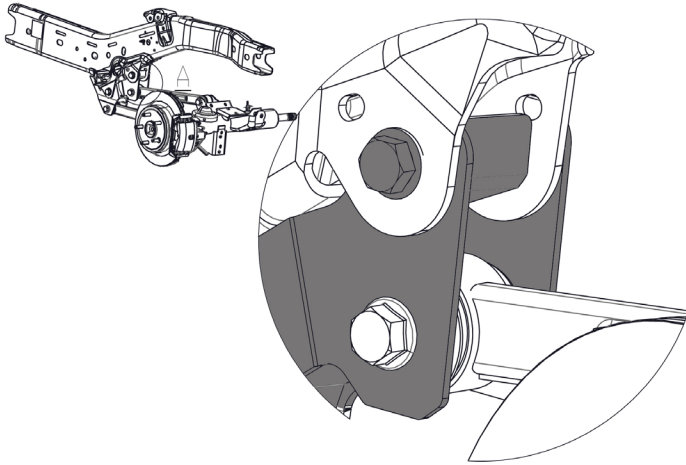
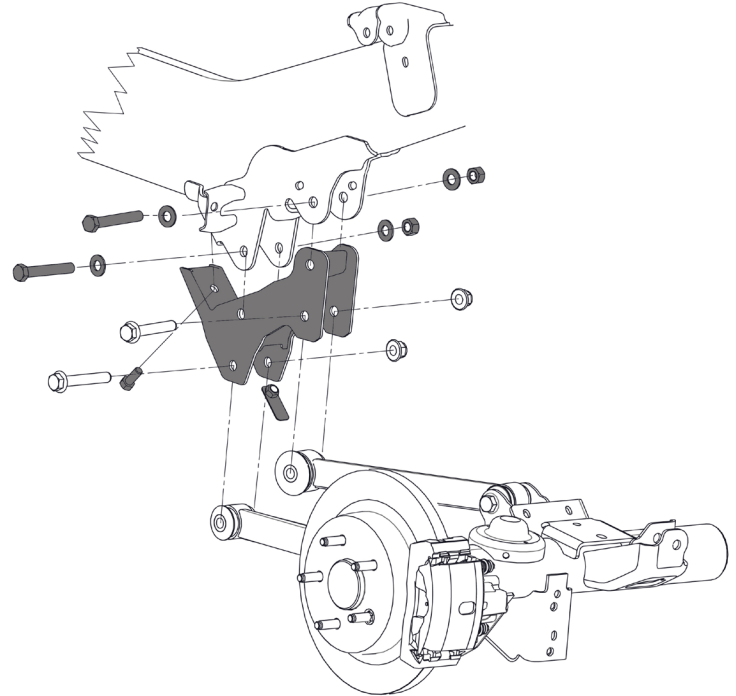
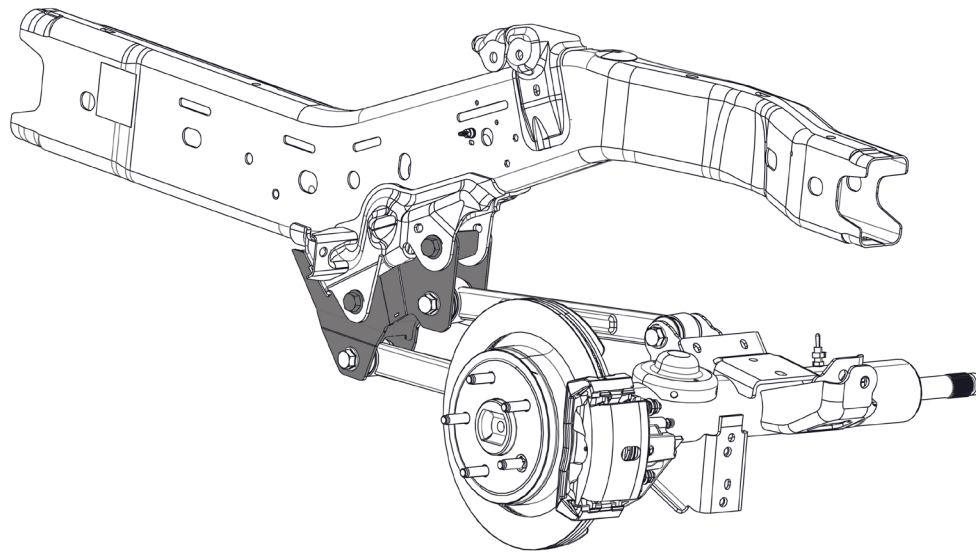
Illustration 10**Illustration 11****Illustration 12**

sides) and Stover nut. Bolt installs from the outside.

B) At upper factory link arm mount, position the 5/8" x 4-1/2" bolt, SAE flat washers (on both nut and bolt head sides) and Stover nut through the front lower mounting hole. Bolt installs from the outside.

C) At hole in front bottom side of Superlift bracket (where bracket mates to bottom of frame rail), insert the 1/2" x 1-1/4" bolt (facing towards rear of vehicle) through the bracket and frame then into the tab nut (SL# 55-12-4540).

□□ Loosely re-attach the factory link arms to the Superlift relocation bracket using factory hardware. Bolts install from the outside. Do not tighten.

□□ Tighten the supplied 5/8" hardware (150) then the supplied 1/2" hardware (55). Do not tighten factory link arm hardware at this time.
30) TRACK BAR BRACKET...[Illustration 13]

□ Mate the Superlift track bar bracket (SL# 55-47-4594), support plate, (SL# 55-22-4594) and sleeve (1-1/8" O.D. x 1-7/16" long) to the factory track bar frame bracket, as shown. The support plate attaches to the rear face of both the factory and Superlift brackets (adding this bracket sandwiches the factory bracket between the "18" and "22" bracket). Insert the supplied 9/16" x 3-1/2" bolt, flat washers (on both nut and bolt head sides), and Nyloc nut. Tighten (105).

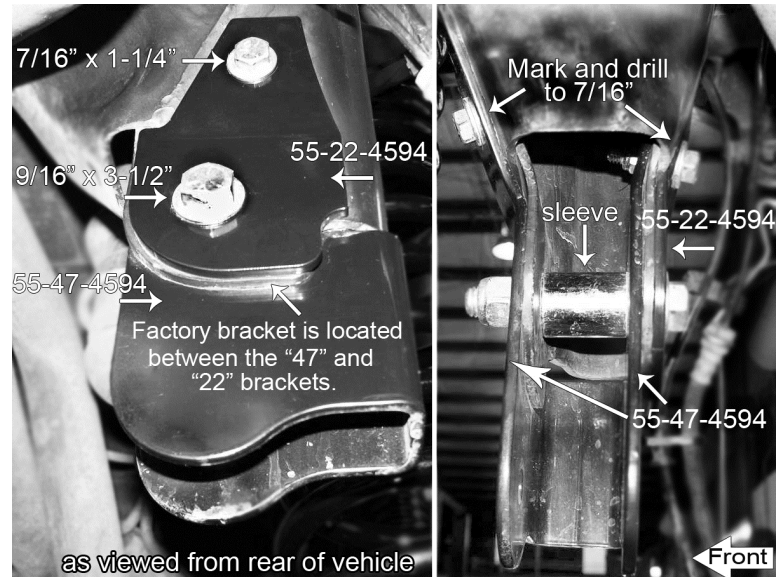
Illustration 13

□ Two 7/16" holes must be drilled through the factory track bar frame bracket. Using the upper hole in Superlift track bar bracket and the support plate as a template, mark and drill. Insert the two supplied 7/16" x 1-1/4" bolt, flat washers (on both nut and bolt head sides), and Nyloc nut. Tighten (50).

31) □□ WHEEL SPEED SENSOR WIRE...[Illustration 14] Remove the Wheel Speed Sensor (WSS) wire's front and rear clips. The front clip is located on the front / outboard side of the shock absorber's lower mount, and the rear clip is on the outside edge of the coil spring's lower seat. Reposition the front clip into the factory rear clip's hole, at the base of the coil spring seat, and discard the

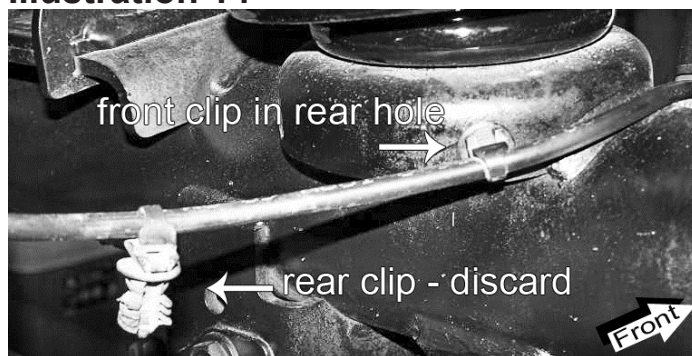
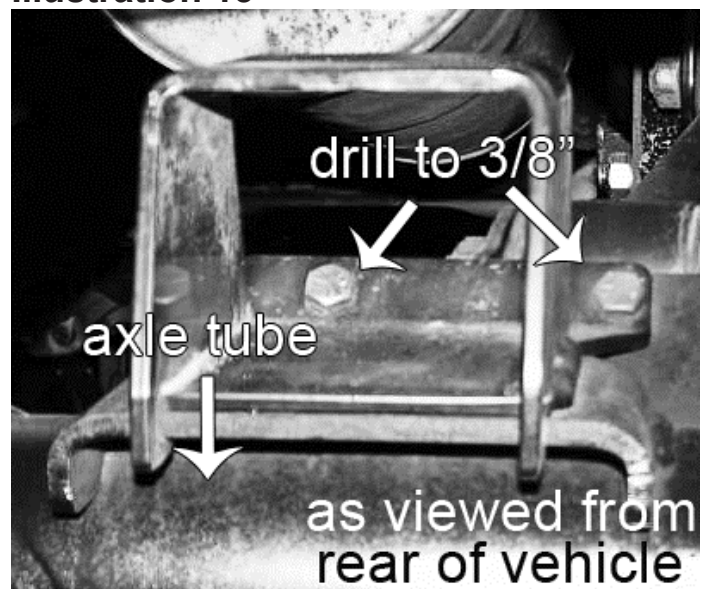
Illustration 14**Illustration 15**

rear clip.

32) BUMP STOPS...[Illustration 15]

□ Position the Superlift passenger side bump stop bracket (SL# 55-36-4594), as shown, on top of the factory bump stop pad, located on top of the axle tube, just inboard of the coil springs. The

“hooks” on the back side of the Superlift bracket capture the underside of the factory bump stop pad. Center the Superlift bracket on the pad then using the holes in the Superlift bracket as a template, drill two holes through the factory pad for the 3/8” mounting hardware. Insert the supplied 3/8” x 1” bolts (installed from top), flat washers (on nut side), and Nyloc nuts. Tighten (30).

□ The Superlift driver side bump stop bracket (SL# 55-37-4594) attaches through pre-existing holes in the factory pad. It uses the same hardware as the passenger side.

33) □ □ COIL SPRINGS AND SHOCKS... Install Superlift coil springs and shock absorbers using the factory hardware and supplied shock bushings and sleeves. Do not tighten. Apply shock decals.

34) BRAKE LINE / ANTI-SWAY BAR BRACKET...

[Illustration 16] Perform this step one side at a time.

□ □ The WSS wire is clipped to the front face of the factory anti-sway bar link’s frame bracket. Detach WSS clip from the bracket.

□ □ Position the Superlift brake line / anti-sway bar relocation bracket (SL# 55-64-4594) over the factory bracket. Use the factory hardware in the top hole, and the supplied 7/16” x 1” bolt, flat washers (on both nut and bolt head sides) and Nyloc nut in the next hole down. Use the supplied 5/16” x 1” bolt, flat washers (on both nut and bolt head sides) and Nyloc nut to attach the factory brake line bracket - to - Superlift bracket. Tighten the 7/16” hardware (50). Tighten the 5/16” hardware (200 in. Lbs.). Tighten the factory hardware (top hole) (23).

□ □ Loosely attach the upper end of the anti-sway bar link to the Superlift bracket using factory hardware. Do not tighten.

□ □ The WSS wire clip, detached in the first step, plugs into a hole in the front face of the Superlift bracket, as shown.

□ □ [Illustration 17] There are three more WSS wire clips per side. Lubricate all then feed the WSS wire up and along the brake hose / line so the end result is as shown.

Illustration 16

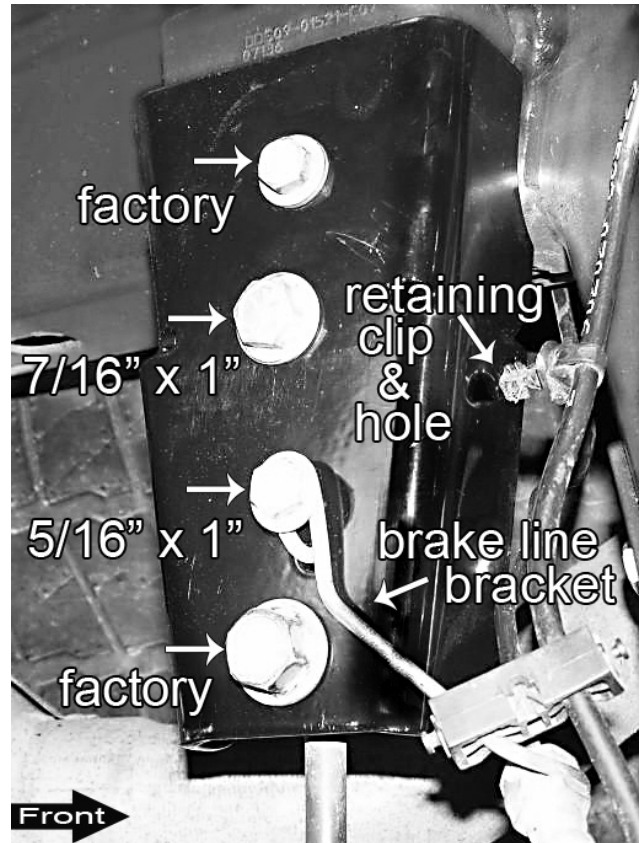
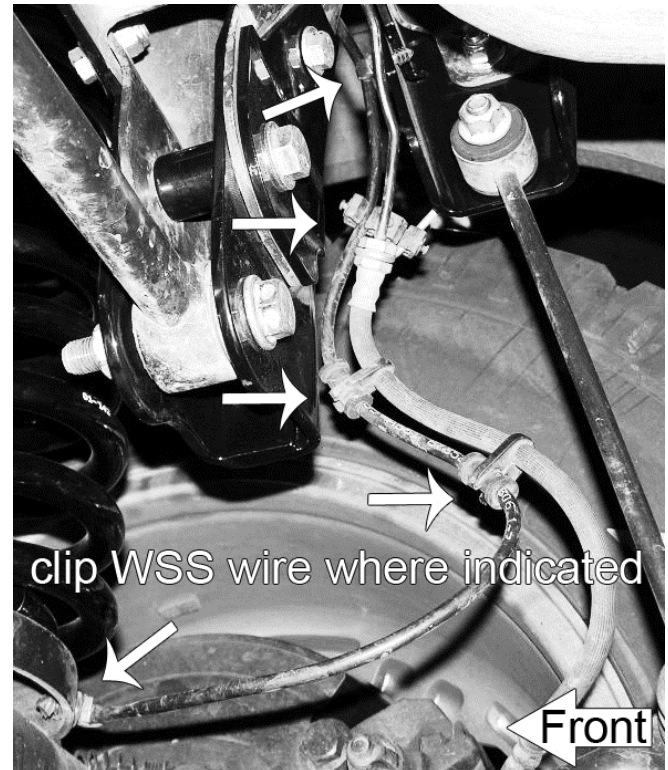

Illustration 17



35) TIRES / WHEELS...[Illustration 10]

Tighten the lug nuts in the sequence shown (130).

WARNING: When the tires / wheels are installed, always check for and remove any corrosion, dirt, or foreign material on the wheel-mounting surface, or anything that contacts the wheel-mounting surface (hub, rotor, etc.). Installing wheels without the proper metal-to-metal contact at the wheel mounting surfaces can cause the lug nuts to loosen and the wheel to come off while the vehicle is in motion.

WARNING: Retighten lug nuts at 500 miles after any wheel change, or anytime the lug nuts are loosened. Failure to do so could cause wheels to come off while vehicle is in motion.

Lower vehicle to the floor. The suspension is now supporting vehicle weight.

36) REAR HARDWARE TIGHTENING SEQUENCE...

Suspension link arms to the Superlift brackets (210). Suspension link arms to the axle (210).

Shock absorbers (100).

Reconnect upper end of track bar using the factory hardware (130). Tighten track bar's lower end

Illustration 18

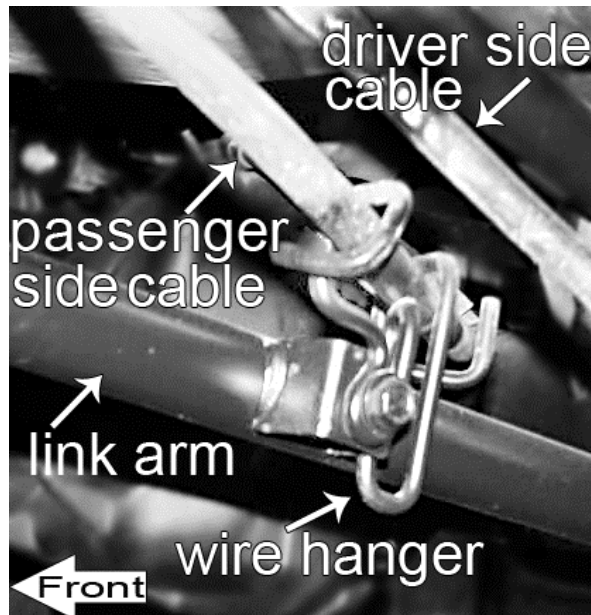
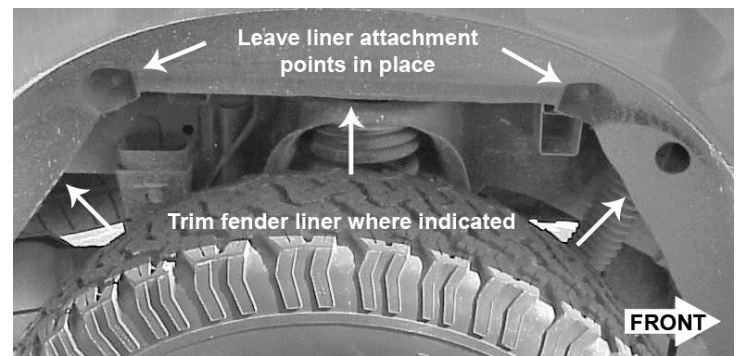

Illustration 19



(130).

Anti-sway bar links to the Superlift brackets (80).

37) PARKING BRAKE CABLES...[Illustration 18] Reattach the parking brake cables' wire hanger bracket to the driver side, lower suspension link arm, but only capture the passenger side cable; leave the driver side cable loose. Tighten the hanger bracket to the link arm bolt (35).

38) REAR WHEEL LINER...[Illustration 19] On trucks equipped with the plastic rear wheel liners the liner may have to be trimmed to minimize contact to the tire. Trim the liner horizontally on the angled face above the area of contact. Leave the two fasteners intact and trim the liner at an angle on each end to meet the bottom of the liner. Paint any exposed surfaces black for best appearance

39) ALIGNMENT...

- Realign vehicle to factory specifications.

40) CLEARANCE CHECK...

- With the vehicle on the ground, check all components for proper operation and clearances. Pay special attention to the clearance between the tires / wheels, brake hoses, wiring, etc.

41) FOUR WHEEL DRIVE...

- Activate the four wheel drive system and check for proper engagement.

42) HEADLIGHTS...

- Re-adjust headlights to proper setting.

43) SUPERLIFT WARNING DECAL...

- Install the WARNING TO DRIVER decal on the inside of the windshield, or on the dash, within driver's view. Refer to the "NOTICE TO DEALER AND VEHICLE OWNER" section below.

44) SUPERLIFT BADGES...

- This kit is packaged with a Superlift badge. Prior to installation, use the supplied alcohol pad to eliminate all soap and or other non-adhering residues that may impair adhesion, thoroughly clean the entire area of placement.
- The adhesive on our badges is pressure sensitive and must be applied using pressure on all areas of the graphic. Like any PSA (pressure sensitive adhesive), it can take up to 72 hours for the adhesive to fully cure. Once the badge is in place do not peel it up, this will diminish the adhesive properties and could result in damaging the badge itself.
- To keep your Superlift badge in "like new" appearance keep the badge free/clear of solvents and chemicals that could cause the adhesive to dry or dissolve. This includes gasoline, diesel fuel, paint thinner, and alcohol. Soap and water is all that is needed for cleaning. Degreasers can be used sparingly and hand whipped/applied if needed, although not suggested.

Important Maintenance Information

It is the ultimate buyer's responsibility to have all bolts / nuts checked for tightness after the first 100 miles and then every 1000 miles. The steering, suspension and driveline systems, plus wheel alignment should be inspected by a qualified professional mechanic at least every 3000 miles.

Limited Lifetime Warranty / Warnings

Your Superlift® product is covered by the Limited Warranty explained below that gives you specific legal rights. This limited warranty is the only warranty Superlift® makes in connection with your product purchase. Superlift® neither assumes nor authorizes any retailer or other person or entity to assume for it any other obligation or liability in connection with this product or limited warranty.

Superlift, LLC, Limited Lifetime Warranty

What is covered? Subject to the terms below, Superlift® will repair or replace its products found defective in materials or workmanship for so long as the original purchaser owns the vehicle on which the product was originally installed. Your warrantor is Superlift, LLC, doing business as Superlift® Suspension Systems (“Superlift®”).

What is not covered? Your Superlift® Limited Warranty does not cover products Superlift® determines to have been damaged by or subjected to:

- Alteration, modification or failure to maintain.
- Normal wear and tear (bushings, rod ends, etc.). Scratches or defects in product finishes (powder coating, plating, etc.).
- Damage to, or resulting from, the vehicle’s electronic stability system, related components or other vehicle systems.
- Racing or other vehicle competitions or contests. Accidents, impact by rocks, trees, obstacles or other aspects of the environment.
- Theft, vandalism or other intentional damage.

Remedy Limited to Repair or Replacement. The exclusive remedy provided hereunder shall, upon Superlift’s inspection and at Superlift’s option, be either repair or replacement of the product covered under this Limited Warranty. Customers requesting warranty consideration should contact Superlift® by phone (1-800-551-4955) to obtain a Returned Goods Authorization number. All removal, shipping and installation costs are customer’s responsibility.

If a replacement part is needed before the Superlift® part in question can be returned, you must first purchase the replacement part. Then, if the part in question is deemed warrantable, you will be credited / refunded.

Other Limitations - Exclusion of Damages - Your Rights Under State Law

- Neither Superlift® nor your independent Superlift® dealer are responsible for any time loss, rental costs, or for any incidental, consequential or other damages you may have.
- This Limited Warranty gives you specific rights, and this is the only warranty Superlift® makes in connection with your product purchase. You may also have other rights that vary from state to state. For example, while all implied warranties are disclaimed herein, any implied warranty required by law is limited to the terms of our Limited Lifetime Warranty as described above. Some states do not allow limitations of how long an implied warranty lasts and / or do not allow the exclusion or limitation of incidental or consequential damages, so the limitations and exclusions herein may not apply to you. Superlift® neither assumes nor authorizes any retailer or other person or entity to assume for it any other obligation or liability in connection with this product or Limited Warranty.

Superlift, LLC, Satisfaction Guarantee

We want you to purchase our product with confidence and be 100% satisfied with the end result. If you have any legitimate issue, and Superlift® cannot rectify it to your satisfaction, Superlift® will take back the Superlift® brand product and refund the customer 100% of the product purchase price.

The details:

- Offer valid to the original retail consumer for six months after product purchase.
- May require a Superlift® dealer's participation in order to assist in "troubleshooting" the issue.
- Any costs related to labor, freight, incidental or consequential are not refunded.
- Refund will not exceed Superlift's® published retail price.

Important Product Use and Safety Information / Warnings

As a general rule, the taller a vehicle is, the easier it will roll over. Offset, as much as possible, what is lost in rollover resistance by increasing tire track width. In other words, go "wide" as you go "tall"; always use as wide a tire and wheel combination as feasible to enhance vehicle stability. We strongly recommend, because of rollover possibility, that the vehicle be equipped with a functional roll bar and cage system. Seat belts and shoulder harnesses should be worn at all times. Avoid situations where a side rollover may occur.

Generally, braking performance and capabilities are decreased when significantly larger / heavier tires and wheels are used. Take this into consideration while driving. Also, changing axle gear ratios or using tires that are taller or shorter than factory height will cause an erroneous speedometer reading. On vehicles equipped with an electronic speedometer, the speed signal impacts other important functions as well. Speedometer recalibration for both mechanical and electronic types is highly recommended.

Do not add, alter, or fabricate any factory or aftermarket parts to increase vehicle height over the intended height of the Superlift® product purchased. Mixing component brands is not recommended.

SUPERLIFT LLC
300 Huey Lenard Loop Rd.
West Monroe, Louisiana 71292
Phone: (318) 397-3000
Sales / Tech: (800) 551-4955
Fax: (318) 397-3040
www.superlift.com